

VENT-O-MAT AIR VALVES ARE DESIGNED TO FULFILL FOUR FUNCTIONS NAMELY:  
 LARGE VOLUME AIR DISCHARGE - PIPELINE FILLING  
 PRESSURIZED AIR DISCHARGE - PIPELINE OPERATING  
 AIR INTAKE (VACUUM BREAKING) PIPELINE DRAINING  
 SURGE PROTECTION - RAPID FILLING OR COLUMN SEPARATION

© Copyright D.F.C. (Pty) Ltd.

**DFC DYNAMIC FLUID CONTROL**  
 32 Lincoln Road, Benoni South, Gauteng, South Africa  
 P.O. BOX 5064, Benoni South, Gauteng, 1502, South Africa  
 Tel: +27 11 748 0200 Fax: +27 11 421 2749  
 email: ventomat@dfc.co.za web: www.ventomat.com

TITLE: <b>DN50 (2") - PN16 VENT - O - MAT</b> <b>RGXII<b>f</b> SERIES DBL ACTING AIR VALVE</b>			
DRAWN: I.M	DATE: 03/05/2022	CHECKED: TT	DATE: 03/05/2022
SCALE: 1:2	A3		
PROJECTION:			
REV.	DATE	SIGN	DESCRIPTION
1	26/7/22	I.M	ADD PORT, MOVE LOWER PORT

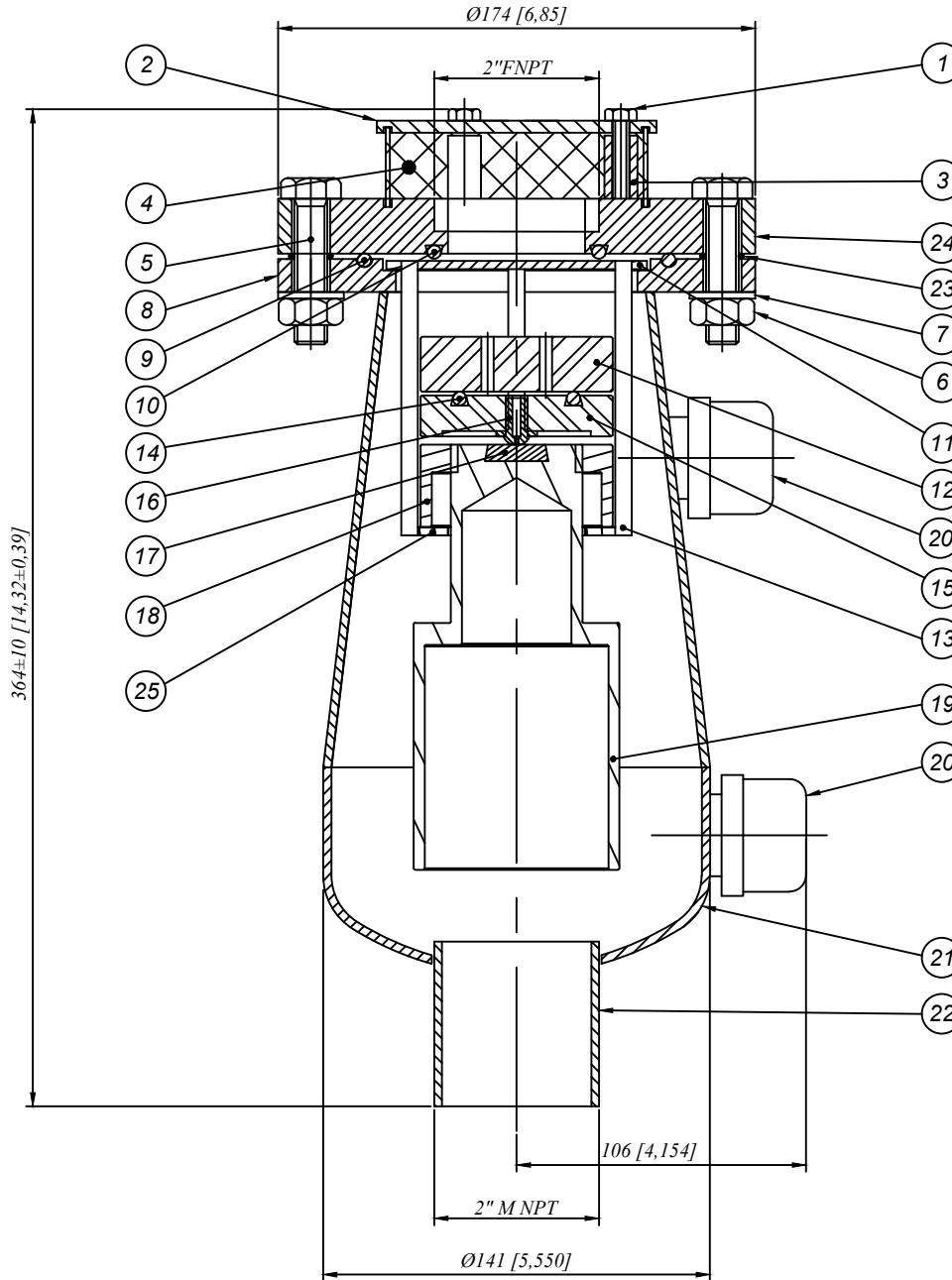

**NOTE:**

1. DIMENSIONS IN BRACKETS ARE IN INCHES
2. OPERATING PRESSURE MIN. 1 PSI TO MAX 232 PSI

DN mm (in)	MODEL No.	WEIGHT #kg (lbs)	VALVE TAG
050 (2")	050 RGXII <b>f</b> 1621	12 (26)	050RGXII1621S6
ITEM	QTY	DESCRIPTION	MATERIAL
1	3	TOP COVER SET SCREW	S/STEEL 316
2	1	TOP COVER	S/STEEL 316
3	3	TOP COVER SPACER	ABS POLYLAC PA 737
4	1	SCREEN MESH	S/STEEL 316
5	4	M12 x 60 FLANGE BOLTS	S/STEEL 316
6	4	M12 HEX NUTS	S/STEEL 316
7	4	M12 WASHERS	S/STEEL 316
8	1	050RGXII <b>f</b> SLIP ON FLANGE	S/STEEL 316
9	1	105 x 5 O-RING	E.P.D.M.
10	1	55 x 5 O-RING	E.P.D.M.
11	1	UPPER CAGE RING	S/STEEL 316
12	1	050RGXII ANTI SHOCK FLOAT	H.D.P.E.
13	4	FLOAT GUIDES	S/STEEL 316
14	1	35 x 5 O-RING	E.P.D.M.
15	1	050RGXII UPPER FLOAT	H.D.P.E.
16	1	025RBX NOZZLE	S/STEEL 316
17	1	025RBX NOZZLE SEAT	E.P.D.M.
18	1	050RGXII LOWER FLOAT TOP	HDPE
19	1	050RGXII LOWER FLOAT	HDPE
20	2	1" PORTS C/W CAPS	S/STEEL 316
21	1	050RGXII <b>f</b> BODY	S/STEEL 316
22	1	050RGXII <b>f</b> NIPPLE	S/STEEL 316
23	4	12 x 2 O-RING	E.P.D.M.
24	1	050RGXII <b>f</b> TOP FLANGE	S/STEEL 316
25	1	LOWER CAGE RING	S/STEEL 316

TYPE: 050 RGXII**f** 1621  
 050RGXII**f**6BS6F27k  
 SHEET 1 OF 1 DRG No: GA REF No: