



COOPERATIVE PURCHASING AGREEMENT FOR TRAFFIC SIGNAL AND STREET LIGHT PAINTING SERVICES

THIS COOPERATIVE PURCHASING AGREEMENT FOR TRAFFIC SIGNAL AND STREET LIGHT PAINTING SERVICES ("Piggyback Agreement") is entered into by and between the CITY OF OCALA, a Florida municipal corporation ("City") and BRETT M. MUSCAT D/B/A/ MUSCAT PAINTING & DECORATING, a for-profit corporation duly organized in the state of Illinois and authorized to do business in the state of Florida (EIN: 06-1778851) ("Contractor").

WHEREAS, after a competitive procurement process, City of Sarasota, Florida ("Sarasota") entered into an Agreement for Traffic Signal and Street Light Painting Services with Muscat Painting & Decorating for the provision of traffic signal and street light painting services, Sarasota contract number ITB 23-11JS (the "Sarasota Agreement"); and

WHEREAS, in accordance with Chapter 287, Florida Statutes and the City of Ocala's contracting and procurement policies and procedures, City has the legal authority to "piggyback" the purchase of goods and services as contracted by another governmental entity as a form of inter-governmental cooperative purchasing when seeking to utilize the same or similar services provided for in said contract; and

WHEREAS, City desires to purchase labor, services, and materials for the provision of traffic signal and street light painting services pursuant to essentially the same terms and conditions provided under the Sarasota Agreement as applicable and amended by the terms and conditions of this Piggyback Agreement; and

WHEREAS, Contractor agrees to extend the terms, conditions, and pricing of the Sarasota Agreement to the City of Ocala, subject to the terms and conditions of the Piggyback Agreement.

NOW THEREFORE, in consideration of the foregoing recitals, the following mutual covenants and conditions, and other good and valuable consideration, City and Contractor agree as follows:

1. **RECITALS.** City and Contractor hereby represent, warrant, and agree that the Recitals set forth above are true and correct and are incorporated herein by reference.
2. **DEFINITIONS.** As used in this Piggyback Agreement, the following terms shall have the meaning specified below:
 - A. **Piggyback Agreement:** shall mean this Cooperative Purchasing Agreement for traffic signal and street light painting services as it may from time to time be amended or modified pursuant to its terms and provisions.
 - B. **Sarasota Agreement:** shall mean the Term Contract for traffic signal and street light painting services between the City of Sarasota and Muscat Painting & Decorating, and its exhibits, as amended and attached hereto as **Exhibit A –Sarasota Agreement**.
3. **INCORPORATION OF SARASOTA AGREEMENT.** The Sarasota Agreement attached hereto as **Exhibit A** is hereby incorporated by reference as if set forth herein in its entirety. However, to the extent that any terms and conditions set forth in the Sarasota Agreement conflict with any of the amended or supplemental terms and conditions set forth in this Piggyback Agreement, then the amended and supplemental terms and conditions set forth in this Piggyback Agreement shall be given precedence.
4. **CONTRACT DOCUMENTS.** The Contract Documents which comprise the entire understanding between City and Contractor shall only include this Agreement and those documents listed in



this section as Exhibits to this Agreement. Each of these documents are incorporated herein by reference for all purposes. If there is a conflict between the terms of this Agreement and the Contract Documents, then the terms of this Agreement shall control, amend, and supersede any conflicting terms contained in the remaining Contract Documents.

Exhibits to Agreement: The Exhibits to this Agreement are as follows:

Exhibit A: Sarasota Agreement (A-1 through A-28)

5. **AMENDED TERMS AND CONDITIONS.** The following terms and conditions of the Sarasota Agreement are modified and replaced, in their entirety, as follows:
- A. The terms "City of Sarasota," or "City" shall be replaced and intended to refer to the "City of Ocala."
 - B. **COMPENSATION.** City shall pay Contractor a price not to exceed the maximum limiting amount of **FORTY-FIVE THOUSAND AND NO/100 DOLLARS (\$45,000)** over the contract term for the performance of the work and in accordance with the contract documents based on the most current prices set forth in **Exhibit A – Sarasota Agreement**.
 - C. **TIME FOR PERFORMANCE.** This Agreement shall become effective and commence on **FEBRUARY 20, 2026** and continue through and including **MARCH 21, 2026**.
 - D. **Invoice Submission.** All invoices submitted by Contractor shall include the City Contract Number, an assigned Invoice Number, and Invoice Date. Contractor shall submit the original invoice through the responsible City Project Manager at: **Public Works Department**, 1805 NE 30th Avenue, Ocala, Florida 34470 Attn: **Nick Blizzard** E-Mail: njblizzard@ocalafl.gov; Office: 352-351-6707.
 - E. **Payment of Invoices by City.** The City Project Manager must review and approve all invoices prior to payment. City Project Manager's approval shall not be unreasonably withheld, conditioned, or delayed. Payments by City shall be made no later than the time periods established in section 218.735, Florida Statutes.
 - F. **Withholding of Payment.** City reserves the right to withhold, in whole or in part, payment for any and all work that: (i) has not been completed by Contractor; (ii) is inadequate or defective and has not been remedied or resolved in a manner satisfactory to the City Project Manager; or (iii) which fails to comply with any term, condition, or other requirement under this Agreement. Any payment withheld shall be released and remitted to Contractor within **THIRTY (30)** calendar days of the Contractor's remedy or resolution of the inadequacy or defect.
 - G. **Excess Funds.** If due to mistake or any other reason Contractor receives payment under this Agreement in excess of what is provided for by the Agreement, Contractor shall promptly notify City upon discovery of the receipt of the overpayment. Any overpayment shall be refunded to City within **THIRTY (30)** days of Contractor's receipt of the overpayment or must also include interest calculated from the date of the overpayment at the interest rate for judgments at the highest rate as allowed by law.
 - H. **Amounts Due to the City.** Contractor must be current and remain current in all obligations due to the City during the performance of services under the Agreement. Payments to Contractor may be offset by any delinquent amounts due to the City or fees and/or charges owed to the City.



- I. **Tax Exemption.** City is exempt from all federal excise and state sales taxes (State of Florida Consumer's Certification of Exemption 85-8012621655C-9). The City's Employer Identification Number is 59-60000392. Contractor shall not be exempted from paying sales tax to its suppliers for materials to fulfill contractual obligations with the City, nor will Contractor be authorized to use City's Tax Exemption Number for securing materials listed herein.
6. **COMMERCIAL AUTO LIABILITY INSURANCE.** Contractor shall procure, maintain, and keep in full force, effect, and good standing for the life of this Agreement a policy of commercial auto liability insurance with a minimum combined single limit of One Million Dollars (\$1,000,000) per occurrence for bodily injury and property damage arising out of Contractor's operations and covering all owned, hired, scheduled, and non-owned automobiles utilized in said operations. If Contractor does not own vehicles, Contractor shall maintain coverage for hired and non-owned automobile liability, which may be satisfied by way of endorsement to Contractor's Commercial General Liability policy or separate Commercial Automobile Liability policy.
7. **GENERAL LIABILITY INSURANCE.** Contractor shall procure and maintain, for the life of this Agreement, commercial general liability insurance with minimum coverage limits not less than:
- A. One Million Dollars (\$1,000,000) per occurrence and Two Million Dollars (\$2,000,000) aggregate limit for bodily injury, property damage, and personal and advertising injury; and
 - B. One Million Dollars (\$1,000,000) per occurrence and Two Million Dollars (\$2,000,000) aggregate limit for products and completed operations.
 - C. Policy must include coverage for contractual liability and independent contractors.
 - D. Policy must include Additional Insured coverage in favor of the City that is no less restrictive than that afforded under the CG 20 26 04 13 Additional Insured Form.
8. **WORKERS' COMPENSATION AND EMPLOYER'S LIABILITY.** Worker's Compensation insurance shall be provided by Contractor as required by Chapter 440, Florida Statutes, or any other applicable state or federal law, including the U.S. Longshoremen's and Harbor Workers Compensation Act and the Jones Act.
- A. Contractor shall similarly require any and all subcontractors to afford such coverage for all of its employees as required by applicable law.
 - B. Contractor shall waive and shall ensure that Contractor's insurance carrier waives, all subrogation rights against the City of Ocala and its officers, employees, and volunteers for all losses or damages. Contractor's policy shall be endorsed with WC 00 03 13 Waiver of our Right to Recover from Others or its equivalent.
 - C. Exceptions and exemptions to this Section may be allowed at the discretion of the City's Risk Manager on a case-by-case basis in accordance with Florida Statutes and shall be evidenced by a separate waiver.
9. **ADDITIONAL INSURANCE REQUIREMENTS.**
- A. Contractor's insurance coverage shall be primary insurance for all applicable policies. The limits of coverage under each policy maintained by Contractor shall not be interpreted as limiting Contractor's liability or obligations under this Agreement. City does not in any way represent that these types or amounts of insurance are sufficient or adequate enough to protect Contractor's interests or liabilities or to protect Contractor from claims that may arise



- out of or result from the negligent acts, errors, or omissions of Contractor, any of its agents or subcontractors, or for anyone whose negligent act(s) Contractor may be liable.
- B. No insurance shall be provided by the City for Contractor under this Agreement and Contractor shall be fully and solely responsible for any costs or expenses incurred as a result of a coverage deductible, co-insurance penalty, or self-insured retention to include any loss not covered because of the operation of such deductible, co-insurance penalty, self-insured retention, or coverage exclusion or limitation.
- C. **Certificates of Insurance.** No work shall be commenced by Contractor under this Agreement until the required Certificate of Insurance and endorsements have been provided nor shall Contractor allow any subcontractor to commence work until all similarly required certificates and endorsements of the subcontractor have also been provided. Work shall not continue after expiration (or cancellation) of the Certificate of Insurance and work shall not resume until a new Certificate of Insurance has been provided. **Contractor shall provide evidence of insurance in the form of a valid Certificate of Insurance (binders are unacceptable) prior to the start of work contemplated under this Agreement to: City of Ocala. Attention: Procurement & Contracting Department, Address: 110 SE Watula Avenue, Third Floor, Ocala Florida 34471, E-Mail: vendors@ocalafl.gov.** Contractor's Certificate of Insurance and required endorsements shall be issued by an agency authorized to do business in the State of Florida with an A.M. Best Rating of A or better. The Certificate of Insurance shall indicate whether coverage is being provided under a claims-made or occurrence form. If any coverage is provided on a claims-made form, the Certificate of Insurance must show a retroactive date, which shall be the effective date of the initial contract or prior.
- D. **City as Additional Insured.** The City of Ocala shall be named as an Additional Insured and Certificate Holder on all liability policies identified in this Section with the exception of Workers' Compensation, Auto Liability (except when required by Risk Management) and Professional Liability policies. **Workers Compensation policy must contain a Waiver of Subrogation in favor of the City.**
- E. **Notice of Cancellation of Insurance.** Contractor's Certificate of Insurance shall provide **THIRTY (30) DAY** notice of cancellation, **TEN (10) DAY** notice if cancellation is for non-payment of premium. In the event that Contractor's insurer is unable to accommodate the cancellation notice requirement, it shall be the responsibility of Contractor to provide the proper notice. Such notification shall be in writing by registered mail, return receipt requested, and addressed to the certificate holder. Additional copies may be sent to the City of Ocala at vendors@ocalafl.gov.
- F. **Failure to Maintain Coverage.** The insurance policies and coverages set forth above are required and providing proof of and maintaining insurance of the types and with such terms and limits set forth above is a material obligation of Contractor. Contractor's failure to obtain or maintain in full force and effect any insurance coverage required under this Agreement shall constitute material breach of this Agreement.
- G. **Severability of Interests.** Contractor shall arrange for its liability insurance to include or be endorsed to include a severability of interests/cross-liability provision so that the "City of Ocala" (where named as an additional insured) will be treated as if a separate policy were in existence, but without increasing the policy limits.
10. **PUBLIC RECORDS.** Contractor shall comply with all applicable provisions of the Florida Public Records Act, Chapter 119, Florida Statutes. Specifically, Contractor shall:
- A. Keep and maintain public records required by the public agency to perform the service.



- B. Upon request from the public agency's custodian of public records, provide the public agency with a copy of the requested records or allow the records to be inspected or copied within a reasonable time at a cost that does not exceed the cost provided in Chapter 119, Florida Statutes, or as otherwise provided by law.
- C. Ensure that public records that are exempt or confidential and exempt from public records disclosure requirements are not disclosed except as authorized by law for the duration of the contract term and following completion of the contract if Contractor does not transfer the records to the public agency.
- D. Upon completion of the contract, transfer, at no cost, to the public agency all public records in possession of Contractor or keep and maintain public records required by the public agency to perform the service. If Contractor transfers all public records to the public agency upon completion of the contract, Contractor shall destroy any duplicate public records that are exempt or confidential and exempt from public records disclosure requirements. If Contractor keeps and maintains public records upon completion of the contract, Contractor shall meet all applicable requirements for retaining public records. All records stored electronically must be provided to the public agency, upon request from the public agency's custodian of public records, in a format that is compatible with the information technology systems of the public agency.

IF CONTRACTOR HAS QUESTIONS REGARDING THE APPLICATION OF CHAPTER 119, FLORIDA STATUTES, TO CONTRACTOR'S DUTY TO PROVIDE PUBLIC RECORDS RELATING TO THIS CONTRACT, CONTACT THE CUSTODIAN OF PUBLIC RECORDS AT: CITY OF OCALA, OFFICE OF THE CITY CLERK; 352-629-8266; E-mail: clerk@ocalafl.gov; City Hall, 110 SE Watula Avenue, Ocala, FL 34471.

- 11. **AUDIT.** Contractor shall comply and cooperate immediately with any inspections, reviews, investigations, or audits relating to this Agreement as deemed necessary by the Florida Office of the Inspector General, the City's Internal or External auditors or by any other Florida official with proper authority.
- 12. **PUBLICITY.** Contractor shall not use City's name, logo, seal or other likeness in any press release, marketing materials, or other public announcement without City's prior written approval.
- 13. **E-VERIFY.** Pursuant to section 448.095, Contractor shall register with and use the U.S. Department of Homeland Security's ("DHS") E-Verify System, accessible at <https://e-verify.uscis.gov/emp>, to verify the work authorization status of all newly hired employees. Contractor shall obtain affidavits from any and all subcontractors in accordance with paragraph 2(b) of section 448.095, Florida Statutes, and maintain copies of such affidavits for the duration of this Agreement. By entering into this Agreement, Contractor certifies and ensures that it utilizes and will continue to utilize the DHS E-Verify System for the duration of this Agreement and any subsequent renewals of same. Contractor understands that failure to comply with the requirements of this section shall result in the termination of this Agreement and Contractor may lose the ability to be awarded a public contract for a minimum of one (1) year after the date on which the Agreement was terminated. Contractor shall provide a copy of its DHS Memorandum



of Understanding upon City's request. Please visit www.e-verify.gov for more information regarding the E-Verify System.

14. **CONFLICT OF INTEREST.** Contractor is required to have disclosed, with the submission of their bid, the name of any officer, director, or agent who may be employed by the City. Contractor shall further disclose the name of any City employee who owns, directly or indirectly, any interest in Contractor's business or any affiliated business entity. Any additional conflicts of interest that may occur during the contract term must be disclosed to the City of Ocala Procurement Department.
15. **WAIVER.** The failure or delay of any party at any time to require performance by another party of any provision of this Agreement, even if known, shall not affect the right of such party to require performance of that provision or to exercise any right, power or remedy hereunder. Any waiver by any party of any breach of any provision of this Agreement should not be construed as a waiver of any continuing or succeeding breach of such provision, a waiver of the provision itself, or a waiver of any right, power or remedy under this Agreement. No notice to or demand on any party in any circumstance shall, of itself, entitle such party to any other or further notice or demand in similar or other circumstances.
16. **SEVERABILITY OF ILLEGAL PROVISIONS.** Wherever possible, each provision of this Agreement shall be interpreted in such a manner as to be effective and valid under the applicable law. Should any portion of this Agreement be declared invalid for any reason, such declaration shall have no effect upon the remaining portions of this Agreement.
17. **INDEMNITY.** Contractor shall indemnify City and its elected officials, employees and volunteers against, and hold City and its elected officials, employees and volunteers harmless from, all damages, claims, losses, costs, and expenses, including reasonable attorneys' fees, which City or its elected officials, employees or volunteers may sustain, or which may be asserted against City or its elected officials, employees or volunteers, arising out of the activities contemplated by this Agreement including, without limitation, harm or personal injury to third persons during the term of this Agreement to the extent attributable to the actions of Contractor, its agents, and employees.
18. **NO WAIVER OF SOVEREIGN IMMUNITY.** Nothing herein is intended to waive sovereign immunity by the City to which sovereign immunity may be applicable, or of any rights or limits of liability existing under Florida Statute § 768.28. This term shall survive the termination of all performance or obligations under this Agreement and shall be fully binding until any proceeding brought under this Agreement is barred by any applicable statute of limitations.
19. **NOTICES.** All notices, certifications or communications required by this Agreement shall be given in writing and shall be deemed delivered when personally served, or when received if by facsimile transmission with a confirming copy mailed by registered or certified mail, postage prepaid, return receipt requested. Notices can be concurrently delivered by e-mail. All notices shall be addressed to the respective parties as follows:

If to Contractor:

Brett M. Muscat D/B/A Muscat Painting & Decorating
 Attention: Brett Muscat
 555 Ashland Avenue
 East Dundee, Illinois 60118
 Phone: 847-361-7182
 E-mail: brett@muscatpainting.com



If to City of Ocala:

Daphne M. Robinson, Esq., Contracting Officer
 City of Ocala
 110 SE Watula Avenue, 3rd Floor
 Ocala, Florida 34471
 Phone: 352-629-8343
 E-mail: notices@ocalafl.gov

Copy to:

William E. Sexton, Esq., City Attorney
 City of Ocala
 110 SE Watula Avenue, 3rd Floor
 Ocala, Florida 34471
 Phone: 352-401-3972
 E-mail: cityattorney@ocalafl.gov

20. **ATTORNEYS' FEES.** If any civil action, arbitration or other legal proceeding is brought for the enforcement of this Agreement, or because of an alleged dispute, breach, default or misrepresentation in connection with any provision of this Agreement, the successful or prevailing party shall be entitled to recover reasonable attorneys' fees, sales and use taxes, court costs and all expenses reasonably incurred even if not taxable as court costs (including, without limitation, all such fees, taxes, costs and expenses incident to arbitration, appellate, bankruptcy and post-judgment proceedings), incurred in that civil action, arbitration or legal proceeding, in addition to any other relief to which such party or parties may be entitled. Attorneys' fees shall include, without limitation, paralegal fees, investigative fees, administrative costs, sales and use taxes and all other charges reasonably billed by the attorney to the prevailing party.
21. **JURY WAIVER.** IN ANY CIVIL ACTION, COUNTERCLAIM, OR PROCEEDING, WHETHER AT LAW OR IN EQUITY, WHICH ARISES OUT OF, CONCERNS, OR RELATES TO THIS AGREEMENT, ANY AND ALL TRANSACTIONS CONTEMPLATED HEREUNDER, THE PERFORMANCE HEREOF, OR THE RELATIONSHIP CREATED HEREBY, WHETHER SOUNDING IN CONTRACT, TORT, STRICT LIABILITY, OR OTHERWISE, TRIAL SHALL BE TO A COURT OF COMPETENT JURISDICTION AND NOT TO A JURY. EACH PARTY HEREBY IRREVOCABLY WAIVES ANY RIGHT IT MAY HAVE TO A TRIAL BY JURY. NEITHER PARTY HAS MADE OR RELIED UPON ANY ORAL REPRESENTATIONS TO OR BY ANY OTHER PARTY REGARDING THE ENFORCEABILITY OF THIS PROVISION. EACH PARTY HAS READ AND UNDERSTANDS THE EFFECT OF THIS JURY WAIVER PROVISION.
22. **GOVERNING LAW.** This Agreement is and shall be deemed to be a contract entered and made pursuant to the laws of the State of Florida and shall in all respects be governed, construed, applied and enforced in accordance with the laws of the State of Florida.
23. **JURISDICTION AND VENUE.** The parties acknowledge that a majority of the negotiations, anticipated performance and execution of this Agreement occurred or shall occur in Marion County, Florida. Any civil action or legal proceeding arising out of or relating to this Agreement shall be brought only in the courts of record of the State of Florida in Marion County or the United States District Court, Middle District of Florida, Ocala Division. Each party consents to the exclusive jurisdiction of such court in any such civil action or legal proceeding and waives any



objection to the laying of venue of any such civil action or legal proceeding in such court and/or the right to bring an action or proceeding in any other court. Service of any court paper may be effected on such party by mail, as provided in this Agreement, or in such other manner as may be provided under applicable laws, rules of procedures or local rules.

24. **REFERENCE TO PARTIES.** Each reference herein to the parties shall be deemed to include their successors, assigns, heirs, administrators, and legal representatives, all whom shall be bound by the provisions hereof.
25. **MUTUALITY OF NEGOTIATION.** Contractor and City acknowledge that this Agreement is a result of negotiations between Contractor and City, and the Agreement shall not be construed in favor of, or against, either party because of that party having been more involved in the drafting of the Agreement.
26. **SECTION HEADINGS.** The section headings herein are included for convenience only and shall not be deemed to be a part of this Agreement.
27. **RIGHTS OF THIRD PARTIES.** Nothing in this Agreement, whether express or implied, is intended to confer any rights or remedies under or because of this Agreement on any persons other than the parties hereto and their respective legal representatives, successors and permitted assigns. Nothing in this Agreement is intended to relieve or discharge the obligation or liability of any third persons to any party to this Agreement, nor shall any provision give any third persons any right of subrogation or action over or against any party to this Agreement.
28. **AMENDMENT.** No amendment to this Agreement shall be effective except those agreed to in writing and signed by both parties to this Agreement.
29. **COUNTERPARTS.** This Agreement may be executed in counterparts, each of which shall be an original and all of which shall constitute the same instrument.
30. **ELECTRONIC SIGNATURE(S).** Contractor, if and by offering an electronic signature in any form whatsoever, will accept and agree to be bound by said electronic signature to all terms and conditions of this Agreement. Further, a duplicate or copy of the Agreement that contains a duplicated or non-original signature will be treated the same as an original, signed copy of this original Agreement for all purposes.
31. **ENTIRE AGREEMENT.** This Agreement, including exhibits, (if any) constitutes the entire Agreement between the parties hereto with respect to the subject matter hereof. There are no other representations, warranties, promises, agreements or understandings, oral, written or implied, among the Parties, except to the extent reference is made thereto in this Agreement. No course of prior dealings between the parties and no usage of trade shall be relevant or admissible to supplement, explain, or vary any of the terms of this Agreement. No representations, understandings, or agreements have been made or relied upon in the making of this Agreement other than those specifically set forth herein.
32. **LEGAL AUTHORITY.** Each person signing this Agreement on behalf of either party individually warrants that he or she has full legal power to execute this Agreement on behalf of the party for whom he or she is signing, and to bind and obligate such party with respect to all provisions contained in this Agreement.



IN WITNESS WHEREOF, the parties have executed this Agreement on 2/16/2026.

ATTEST:

Signed by:
Angel B. Jacobs
8DB3574C28E54A5...
Angel B. Jacobs
City Clerk

CITY OF OCALA

DocuSigned by:
Ken Whitehead
5677F71E38874F4...
Ken Whitehead
Assistant City Manager

Approved as to form and legality:

Signed by:
William E. Sexton, Esq.
4A55AD8A8ED04F3...
William E. Sexton, Esq.
City Attorney

BRETT M. MUSCAT D/B/A/ MUSCAT PAINTING & DECORATING

DocuSigned by:
Muscat Painting & Decorating
B9C72D8E78EC401...

By: Muscat Painting & Decorating
(Printed Name)

Title: Administrator
(Title of Authorized Signatory)

AGREEMENT FOR TRAFFIC SIGNAL AND STREET LIGHT PAINTING SERVICES

THIS AGREEMENT FOR TRAFFIC SIGNAL AND STREET LIGHT PAINTING SERVICES, made and entered into on 22 March 2023 by and between the CITY OF SARASOTA, FLORIDA, a municipal corporation, hereinafter referred to as “CITY,” and BRETT M. MUSCAT D/B/A MUSCAT PAINTING & DECORATING, hereinafter referred to as “CONTRACTOR”.

W I T N E S S E T H :

WHEREAS, CITY has publicly announced an Invitation to Bid seeking a vendor to furnish all labor, supervision, equipment, vehicles and materials as necessary to provide complete service to clean, prime and paint various types of traffic signal and street light equipment at various locations throughout CITY on an as-needed basis pursuant to Invitation to Bid No. 23-11JS; and

WHEREAS, CONTRACTOR has submitted a proposal which has been accepted by CITY to provide CITY with said services; and

WHEREAS, CITY and CONTRACTOR desire to enter into this Agreement for Traffic Signal and Street Light Painting Services so as to set forth the terms and conditions upon which CONTRACTOR will provide said services for CITY on an as-needed basis.

NOW, THEREFORE, IN CONSIDERATION OF THE FOREGOING AND THE MUTUAL COVENANTS CONTAINED HEREIN, IT IS AGREED AS FOLLOWS:

1. Definitions: The following terms have the meanings herein ascribed to them:

A. City Manager means the City Manager of the City of Sarasota, Florida, or his designee.

B. Director means the Director of the Public Works Department of the City of Sarasota, or his designee.

C. Project Scope of Services means the Scope of Services to be performed by CONTRACTOR pursuant to this Agreement. The Project Scope of Services includes all labor, supervision, equipment, vehicles, and materials necessary to provide complete service to clean, prime, and paint various types of traffic signal and street light equipment at various locations

throughout CITY on an as-needed basis. A more detailed description of the Project Scope of Services is set forth in the Minimum Specifications and Technical Specifications included within Invitation to Bid #23-11JS, with a photocopy thereof attached hereto and incorporated by reference herein as Exhibit A. CONTRACTOR covenants to provide the Project Scope of Services in strict conformance with Exhibit A. CONTRACTOR thereby covenants to provide any or all of the tasks and subtasks identified within Exhibit A. CONTRACTOR will provide the Project Scope of Services in strict conformance with Invitation to Bid No. 23-11JS, a copy of which is on file in the Offices of the Financial Administration Purchasing Division of CITY and is deemed incorporated into this Agreement. CONTRACTOR covenants to strictly comply with all of the terms and conditions of Invitation to Bid No. 23-11JS. This includes, but is not limited to, the insurance and indemnification requirements set forth therein. In the event of any conflict between the terms set forth in the main body of this Agreement and Invitation to Bid No. 23-11JS, the terms and conditions set forth in the main body of this Agreement will control, followed by the terms and conditions set forth within Exhibit A, followed by the terms and conditions set forth within Exhibit B, followed by the terms and conditions set forth within Invitation to Bid No. 23-11JS.

2. Project Scope of Services: CONTRACTOR will provide the Project Scope of Services as instructed by the Director on an as-needed basis pursuant to a schedule approved, in advance, in writing by the Director. The Director will be responsible for providing CONTRACTOR notice as to when and where the Project Scope of Services will be required. The Director will cause a Purchase Order to be prepared which identifies any specific Project Scope of Services desired by CITY and to be provided by CONTRACTOR. The Purchase Order will include the specific components of the Project Scope of Services and will set forth the schedule upon which said services must be provided by CONTRACTOR. The Purchase Order will also

specifically identify the locations at which such Project Scope of Services will be provided. CONTRACTOR will not commence any of the Project Scope of Services until a notice to proceed has been provided by the City Manager. CONTRACTOR covenants that the Project Scope of Services must be completed to the satisfaction of the City Manager. There is no assurance as to any minimum amount of Project Scope of Services to be provided by CONTRACTOR. Consequently, there is no assurance that CITY will purchase from CONTRACTOR any minimum amount of Project Scope of Services. The City Manager will be entitled at all times to be advised, in writing, at his request, as to the status of work being done by CONTRACTOR and the details thereof. If CONTRACTOR cannot satisfy any deadlines or provide the Project Scope of Services to the satisfaction of the City Manager, then CONTRACTOR must notify the City Manager in writing at least seven (7) days prior to such deadline of the reason for the delay or the reason for inability to provide the Project Scope of Services.

3. Payment: CITY agrees to pay CONTRACTOR for the Project Scope of Services based upon the unit prices set forth in the Itemized Bid Tabulation submitted by CONTRACTOR in response to Invitation to Bid No. 23-11JS. A photocopy of said Itemized Bid Tabulation is attached hereto and incorporated by reference herein as Exhibit B. Exhibit B will be used to determine the unit prices (not the total prices) to be paid CONTRACTOR for the Project Scope of Services provided by CONTRACTOR to CITY. The fees set forth in this Section 3 include any and all reimbursable expenses and costs incurred in retaining subcontractors or any other costs incurred in performing the Project Scope of Services. CITY will pay CONTRACTOR the invoice amount within thirty (30) days of receipt of a full and complete invoice to the satisfaction of the City Manager. CONTRACTOR may invoice CITY no more often than monthly. The amount set forth in each invoice must be consistent with the unit prices set forth in this Section 3. No amount

of compensation, unless authorized by this Section 3, will be due and payable from CITY to CONTRACTOR.

4. Term: The term of this Agreement will commence upon complete execution by each of the parties. The initial term of this Agreement will be for a period of three (3) years. CITY may renew this Agreement for up to two (2) additional one-year periods upon the mutual agreement of the parties. The City Manager is hereby authorized to administratively approve and execute any of these Agreement extensions so long as there is no increase in the cost or fees to be paid by CITY.

5. Termination Without Default: The City Manager has the right at any time upon thirty (30) days written notice to CONTRACTOR to terminate the services of CONTRACTOR hereunder for any reason whatsoever. In the event of such termination, CITY will be responsible to CONTRACTOR only for the fees and compensation earned by CONTRACTOR prior to the effective date of said termination. In no event will CITY be responsible for lost profits of CONTRACTOR or any asserted damages which may arise out of an alleged premature termination of this Agreement. CONTRACTOR acknowledges that the thirty (30) day notice provision set forth in this Section 5 is adequate additional consideration supporting this termination for convenience clause.

6. Compliance with Applicable Law: This Agreement is governed by the laws of the State of Florida. CONTRACTOR covenants to promptly comply with all applicable federal, state, county and municipal laws, ordinances, regulations, and rules relating to the services to be performed hereunder and in effect at the time of performance. CONTRACTOR covenants that it will conduct no activity or provide any service that is unlawful or offensive.

7. Public Records: As required by Section 119.0701, Florida Statutes, CONTRACTOR hereby specifically covenants to comply with the public records laws of the State of Florida. CONTRACTOR specifically covenants to:

(a) Keep and maintain public records required by CITY in order to perform the Project Scope of Services.

(b) Upon request from CITY, provide CITY with a copy of the requested records or allow the records to be inspected or copied within a reasonable time at a cost that does not exceed the cost provided in Chapter 119, Florida Statutes, or as otherwise provided by law.

(c) Ensure that public records that are exempt or confidential and exempt from public records disclosure requirements are not disclosed except as authorized by law for the duration of the Agreement term and following completion of the Agreement if CONTRACTOR does not transfer the records to CITY.

(d) Upon completion of the Agreement, transfer, at no cost, to CITY all public records in possession of CONTRACTOR or keep and maintain public records required by CITY to perform the Project Scope of Services. If CONTRACTOR transfers all public records to CITY upon completion of the Agreement, CONTRACTOR shall destroy any duplicate public records that are exempt or confidential and exempt from public records disclosure requirements. If CONTRACTOR keeps and maintains public records upon completion of the Agreement, CONTRACTOR shall meet all applicable requirements for maintaining public records. All records stored electronically must be provided to CITY upon request from CITY in a format that is compatible with the information technology systems of CITY.

(e) IF CONTRACTOR HAS QUESTIONS REGARDING THE APPLICATION OF CHAPTER 119, FLORIDA STATUTES, TO THE CONTRACTOR'S DUTY TO PROVIDE PUBLIC RECORDS RELATING TO THIS AGREEMENT, CONTACT THE CUSTODIAN OF PUBLIC RECORDS AT:

SHAYLA GRIGGS, CITY AUDITOR AND CLERK
SHAYLA.GRIGGS@SARASOTAFL.GOV
(941) 263-6385
1565 FIRST STREET
SARASOTA, FL 34236

CONTRACTOR acknowledges that, pursuant to Section 119.0701(3)(b), Florida Statutes, if CONTRACTOR fails to comply with CITY'S request for public records, CITY shall enforce the contract provisions in accordance with the contract. CONTRACTOR acknowledges the relief available to CITY includes, but is not limited to, an action for specific performance.

8. Employment Eligibility: By entering into this Agreement, CONTRACTOR becomes obligated to comply with the provisions of Section 448.095, Florida Statutes, entitled "Employment eligibility." This obligation includes, but is not limited to, utilization of the E-Verify System to verify the work authorization status of all newly hired employees and requiring all subcontractors to provide an affidavit attesting that the subcontractor does not employ, contract with or subcontract with an unauthorized alien. Failure to comply with this Section 8 will result in termination of this Agreement. If a subcontractor knowingly violates Section 448.095, Florida Statutes, the subcontractor must be immediately terminated by CONTRACTOR. Pursuant to Section 448.095, Florida Statutes, any legal challenge to termination must be filed in the Circuit Court of Sarasota County no later than twenty (20) calendar days after the date of termination. If this Agreement is terminated because CONTRACTOR violated Section 448.095, Florida Statutes, CONTRACTOR cannot be awarded a public contract for a period of one (1) year after the date of said termination.

9. Disclaimer of Joint Venture: CONTRACTOR and CITY warrant and represent by the execution of this Agreement it is not the intent of the parties that this Agreement be construed or deemed to represent a joint venture or undertaking between CITY and CONTRACTOR. CONTRACTOR is solely responsible for the conduct of all activities and services provided by CONTRACTOR as part of its business operations. While engaged in carrying out and complying with the terms of this Agreement, CONTRACTOR is an independent contractor and not an officer

or employee of CITY. CONTRACTOR will not at any time or in any manner represent that it or any of its agents or employees are employees of CITY.

10. Right of Inspection: The City Manager has the right at all reasonable times during the term of this Agreement to inspect or otherwise evaluate the work being performed hereunder and the premises in which it is being performed.

11. Remedies - Cumulative: All remedies conferred to CITY are cumulative and no one exclusive of the other, or any other remedy conferred by law.

12. Waiver: The failure of CITY to take any action with respect to any breach of any term, covenant, or condition contained herein, or any instance of default hereunder by CONTRACTOR, will not be deemed to be a waiver of any default or breach by CITY.

13. Entire Agreement: This Agreement, including Invitation to Bid No. 23-11JS on file at the office of the Financial Administration Purchasing Division of CITY constitutes the entire agreement between the parties. All amendments to this Agreement will be ineffective unless reduced to writing as a formal amendment to this Agreement and executed by CITY and CONTRACTOR.

14. Attorney's Fees: Should it be necessary for either party to bring any action against the other alleging a breach of this Agreement or seeking to enforce any of the covenants, provisions, or conditions of this Agreement, the non-prevailing party hereby agrees to pay all costs attendant thereto, including reasonable attorney's fees to the attorney representing prevailing party, and said obligation applies to declaratory relief, if necessary, to interpret any of the terms hereof.

15. Public Entity Crimes: Prior to entering into this Agreement, CONTRACTOR shall file a sworn statement with the Purchasing Manager of CITY, as required by §287.133, Florida Statutes.

16. Notices: Notices and other correspondence required by this Agreement must be sent by certified mail, return receipt requested, to the respective parties at the following addresses:

City of Sarasota
Attention: City Manager
1565 First Street
Sarasota, Florida 34236

Muscat Painting & Decorating
555 Ashland Avenue
East Dundee, Illinois 60118
Attn: Brett M. Muscat, Owner

IN WITNESS WHEREOF this Agreement has been signed and sealed, in duplicate, by the respective parties hereto.

DATED on 22 March 2023 by the **City of Sarasota, Florida.**

DATED on 23 February 2023 by **Brett M. Muscat d/b/a Muscat Painting & Decorating.**

CITY OF SARASOTA, FLORIDA

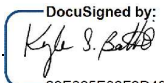
By:  _____
DocuSigned by:
29E865E08F9D495...
Kyle Battie
Mayor

ATTEST:

By:  _____
DocuSigned by:
CDE4CA15935542F...
Shayla Griggs
City Auditor and Clerk

Approved as to form and correctness

By:  _____
DocuSigned by:
034BE83CD0D6440...
Robert Fournier
City Attorney

**BRETT M. MUSCAT D/B/A MUSCAT
PAINTING & DECORATING**

By: ^{DocuSigned by:} Brett Muscat
_{B9C72D8E78EC401...}
Brett M. Muscatt
Owner

Tammy/Agreements/K-O/Muscat (2/13/23)

**ITB #23-11JS
Traffic Signal and Street Lights Painting**

I. MINIMUM SPECIFICATIONS

A. SCOPE OF WORK

The successful bidder shall furnish all labor, supervision, equipment, vehicles, and materials as necessary to provide complete service to clean, prime, and paint various types of traffic signal and street light equipment at various locations throughout the City of Sarasota.

B. INSTRUCTIONS TO BIDDERS

1. All work shall conform to all existing City of Sarasota Codes, Specifications, Technical and Special Provisions, Regulations including lockout/tag-out procedures, Steel Structures Painting Council's Good Painting Practices, Systems and Specifications, and O.S.H.A. standards. If any regulations, codes, specifications, provisions, or standards conflict, the more stringent shall govern. The work must be accomplished with professional methods and standards of the trade.

2. Upon receipt of a purchase order for a project, the Contractor shall complete the project within the contract days of the specific work assignment. Contract days of the specific work assignment shall commence no later than 30 (thirty) days after Contractor receives the work assignment, but work shall not commence until Notice to Proceed is provided by the City of Sarasota. Notice to Proceed, by document via facsimile or e-mail, will not be granted until MOT plans, and other pre-construction activities have been submitted to and approved by City of Sarasota or their authorized representative.

3. Call back or follow-up work to correct previous work, WILL NOT be charged to the City if the work is the result of improper repairs or installation of substandard parts or materials furnished by the Contractor.

4. Maintenance of Traffic personnel, equipment, and material shall be provided, installed, maintained and removed in accordance with current FDOT, MUTCD and City of Sarasota Standards. All costs related to MOT shall be considered incidental to the work and no additional line items will be provided. If conflict occurs between entities, the more stringent will govern.

C. SUPERVISION AND INSPECTION

Items of work will be inspected a minimum of three (3) times by a representative of Traffic Operations.

1. After they have been cleaned.
2. After they have been primed.
3. After the finish coat(s) have been applied.

The Contractor shall notify Public Works, Traffic Operations, forty-eight (48) hours prior to commencement of any work activities. In addition, the Contractor shall notify the designated representative of Traffic Operations 24 hours prior to the prime and finish coats being applied.

D. RESPONSIBILITY OF THE CONTRACTOR FOR POLE PAINTING

The Contractor shall be responsible for any damage due to negligence on his part to any person(s) and/or property while performing work under this contract.

The Contractor shall provide vehicles and equipment for the use of his work force and that are properly equipped for performance of the work, as determined solely by the City of Sarasota Traffic Operations.

E. BILLING INVOICES

Upon completion of the project, the Contractor shall mail or deliver to Traffic Operations a work order and copy of invoice. The original invoices shall be mailed or delivered to the City of Sarasota, Public Works, 1761 12th Street, Sarasota, FL 34236.

F. WORK EXPERIENCE REQUIREMENTS

The Contractor shall have a minimum of three (3) years' experience in the cleaning and painting of aluminum, galvanized steel and steel structures, in cleaning and painting traffic signal and street light pole assemblies. All equipment necessary to perform this contract (i.e. sandblasting equipment, bucket trucks, and containment equipment) shall be owned or leased and operated by the Contractor for the entire length of the contract.

G. CERTIFICATIONS

1. Contractor shall have on his staff a person with the Florida Advanced MOT Qualification and all employees utilized for flagging operations shall have proper flagging certification as recognized and accepted by FDOT.
2. Contractor shall have an employee which holds a current NACE Certified Coating Inspector-Level 1 Certification.

H. SUBCONTRACTOR

The Contractor shall not subcontract any work as required under this contract, unless approved by the City.

I. REQUIRED BID SUBMITTALS

1. **The bidder is required to bid on all line items** on the Electronic Bid Form in order for their bid to be considered responsive. Electronic Bid Form must be uploaded with bid submittal.
2. Florida Advanced MOT Qualifications and holder's names
3. Flagging Certifications
4. NACE Certified Coating Inspector-Level 1 Certification
5. State of Florida Divisions of Corporations Registration Proof

J. CONTRACT TERM

The initial contract period shall be for **three (3) years, with the option to be extended for two (2) additional one (1) year periods**, upon mutual consent of both parties.

K. CONTRACT PRICING

Contract prices to be paid in the initial term of the Agreement will not change from the bid amount. At least sixty (60) days prior to the contract term renewal date, Contractor may request a price adjustment to be applicable during a renewal term. Contractor must, with the request for the price adjustment, provide written justification for any increase in contract prices. The price adjustment is subject to written approval of the City memorialized in a written amendment to the Agreement. Under no circumstances will the City approve a price adjustment which exceeds the contract price for the preceding twelve (12) months by three (3) percent or more. No retroactive price adjustments will be approved by the City. If the Contractor fails to submit a written request for a price adjustment at least sixty (60) days prior to the contract term renewal date, the current contract pricing will remain in effect during any contract renewal term.

II. TECHNICAL SPECIFICATIONS

- A. The Contractor shall assure conditions on the work site reflect good housekeeping and safety practices at all times.

- B. All coatings shall be free from peeling, cracking, bubbling, flaking or other defects due to application failure for a period of one (1) year. Any additional warranty by the coating manufacturer will be forwarded to the City.
- C. The MOT plan may be submitted by Contractor. The Contractor shall provide a Traffic Control Plan, prepared by and signed and sealed by a licensed Florida Professional Engineer who has successfully completed advanced training in Maintenance of Traffic. The plan shall be site specific unless the work requires nothing more than a direct application of a current Florida Department of Transportation (FDOT) 600 standard index. The plans shall indicate a traffic control plan for each phase of the Contractor's activities with all barricades, construction signage, work zone signs, and advance warning arrow panel, flaggers, etc. The Contractor may not begin work until a traffic control plan is approved in writing by the City Engineer's representative.

The approved Traffic Control Plan may be modified to fit field conditions by a person who has successfully completed advanced training in Maintenance of Traffic, but if modification changes the concept of the approved MOT, it is required to be prepared by and signed and sealed by a qualified Florida Professional Engineer as mentioned above. Except in an emergency, no changes to the approved plan are allowed until written approval is received.

A Maintenance of Traffic plan shall be provided no less than ten (10) business days prior to start of construction.

- D. This bid for services describes the work and materials required to clean, prime, and paint the surfaces of signal poles, pedestrian poles, street light poles, mast arms, and other appurtenances utilized in traffic signal and street light operations located within the City of Sarasota. For each work assignment, Traffic Operations will provide to the Contractor a drawing of locations indicating structures to be refinished and the colors required.
- E. The Contractor shall not clean, prime, or paint appurtenances that have not previously been painted. For example, the Contractor is asked to clean, prime, and paint a signal head. The back plate is constructed of a polyvinyl-type material and the mounting hardware is constructed of bare aluminum.
- F. All operations and tasks performed by the Contractor shall comply with the specifications and business practices set forth in the Steel Structures Painting Council's Systems and Specifications, Seventh Edition and Good Painting Practice, Third Edition Manuals or most current edition.
- G. Street name signs shall be bagged during cleaning operation but shall be un-bagged during painting operations. All other signage and signal heads shall remain in operation and shall not be bagged or otherwise covered.
- H. Material shall be used and applied in strict accordance with the manufacturer's directions. No coatings shall be applied to pole surfaces unless they are free from rain, dew or other moisture or as per manufacturer's recommendations. Furthermore, no coatings shall be applied if they cannot be expected to dry before any precipitation is reasonably predicted.
- I. Traffic control signs and signal heads attached to poles shall keep free of paint. All signs, signals and other pertinence attached to mast arms and poles shall be kept free of paint. All signs, signals and other pertinences attached to mast arms and poles defaced or damaged by paint or by cleaning procedures shall be replaced by City crews at the Contractor's expense.
- J. Signal Heads as stated herein shall refer to or consist of a 3 section, 5 section or pedestrian head, or any combination thereof.

- K. Decorative Street Light Pole as stated herein shall refer to the base pole. Typical detail sheets have been provided for reference.
- L. All paint and primer shall be applied with either a brush or a roller in accordance with SSPC standards and the manufacturer's recommendations. Spray is only acceptable for poles, mast arms and other items transported to the Contractor's site for material application. Bid items 36 through 58 on the Bid Form are for items to be cleaned, primed, and painted at the Contractor's facility. Contractor is not responsible for delivery to or from the Contractor's facility. Delivery shall be by others.
- M. All activities of work shall normally be performed Monday through Friday, 7:00 a.m. through 7:00 p.m. Traffic Operations reserves the right to restrict any or all activities of work at major and/or congested intersections to off-peak hours.
- N. When specifications cited or reference herein conflict, the more stringent shall govern.
- O. CLEANING
1. All steel structures shall be cleaned in accordance with the Joint Surface Preparation Standards SSPC- SP 6/NACE No. 6 Commercial Blast Cleaning, unless approved by Traffic Operations as described in Item 5. below.
 2. Containment of materials shall be in accordance with the Class 3A classification as referenced in SSPC-Guide 6. Any and all debris cleaned from the poles, masts and appurtenances, including blasting media shall be removed from the site by the Contractor before leaving the site on a daily basis.
 3. Ventilation within a confined area for offsite cleaning shall be in conformance with Class 4A classification in SSPC-Guide 6 or as required by others. In case of conflict, the more stringent shall govern.
 4. Blasting material shall be "Black Beauty" or equal as approved by Traffic Operations so to minimize airborne dust.
 5. Cleaning procedures may also be or include the following types as approved by Traffic Operations:
 - a. Solvent Cleaning-SSPC-SP 1: Solvent cleaning is a method for removing all visible oil, grease, soil, drawings and cutting compounds and other soluble contaminants from steel structures. It is intended that solvent cleaning be used prior to the application of paint and in conjunction with surface preparation methods specified for the removal of rust, mill scale or paint.
 - b. Power Tool Cleaning-SSPC-SP 3: Power tool cleaning is a method of preparing steel surfaces by the use of power assisted hand tools. Power tool cleaning removes all loose mill scale, loose rust, loose paint, and other loose detrimental foreign matter. It is not intended that adherent mill scale, rust and paint be removed by this process. Mill scale, rust, and paint are considered adherent if they cannot be removed by lifting with a dull putty knife. SSPC-VIS 3, ISO 8501- 1:1988 or other visual standards of surface preparation agreed upon by the contracting parties may be used to further define the surface.
 - c. Any combination of these cleaning methods can be utilized within a specific work assignment. If the more intensive cleaning combination is over 20% of the

structure, then the work assignment will be authorized for more intensive cleaning method.

For example: A structure is to be cleaned utilizing cleaning method SSPC-SP 1- Solvent Cleaning but has some areas of rust that need to be cleaned utilizing SSPC-SP 3-Power Tool Cleaning. If the areas to be cleaned utilized SSPC-SP 3-Power Tool Cleaning are less than 20% of the structure, the work assignment will be authorized for SSPC-SP-1 Solvent Cleaning and the other areas shall be considered incidental. If the areas to be cleaned utilizing SSPC-SP 3 are 20% or more, then the work assignment shall be authorized for SSPC-SP 3. Also, different cleaning methods can be utilized on different poles within the same intersection. The specific work assignment will indicate the City's intent of method to be used but reserves the right to modify the specific work assignment in the case of unforeseen areas.

- d. Inspections of steel structure will be gauged by the most current Steel Structures Painting Council's guidelines.
- P. PRIMING
The entire item of work shall be coated with one (1) coat of Ameron's Amerlock 400 high-solids epoxy coating. The coat shall have a uniform dry film thickness of 4 to 8 mils and be applied per manufacturer's specifications or better.
- Q. PAINTING
The entire item of work shall be coated with two (2) coats of Ameron's PSX 700 engineered siloxane coating. Each coat shall have a uniform dry film thickness of 3 to 7 mils and be applied per manufacturer's specifications or better.
- R. MATERIALS
The two (2) coats of Ameron's PSX 700 shall normally be either Brown RT-1402 or Black BK-1 or Sherman Williams Hunt Club Green #6468. The City reserves the right to require the use of other colors specific to certain work items. The color shall be specified on the location drawing or work assignment to be provided by the City.
- Notwithstanding information and specifications provided by the Contractor, the City Engineer or his approved designee, reserves the right to reject any or all materials or equipment which in his opinion are not suitable for their intended use.
- S. SAFETY
1. The Contractor shall, at all times, take proper precautions (i.e. barricades, tape, warning signs, etc.) to protect the public from paint splatter or injury to that may result from work in progress and from the storage of the materials, tools and equipment within City of Sarasota and/or FDOT right-of-ways.
 2. No equipment shall be stored overnight within the City/County or FDOT right-of-ways without prior approval of the City of Sarasota Traffic Operations. If approved, stored equipment and materials in the right-of-way shall have proper barricades, signage, etc., in accordance with FDOT specifications.
 3. All debris and waste shall be disposed of properly in accordance with City, State and Federal guidelines and removed from the site on a daily basis. In the case of conflict, the more stringent shall apply.
 4. Contractor shall at all times be in compliance with current OSHA regulations and solely responsible to supervise work crews for compliance.

T. LOCATION OF WORK

1. The City will provide drawings to the Contractor with the locations of the items to be painted when the work assignment is issued.
2. The City will require a field visit of each location with the Contractor prior to issuance of the Purchase Order.
3. The contract will also be used for coating of structures at the Contractor's place of business. The Contractor will not be responsible for delivery of structures to be coated to or from his/her place of business, but will be responsible for the proper storage, handling, and security of said structures while at the Contractor's place of business. Line items 36 through 58 have been provided for the tasks of cleaning, priming and painting of items at the Contractor's place of business.
4. The Contractor shall have a place of business that provides for proper storage and security measures as approved by the City's Traffic Operations. The facilities must be suitable for the type of work being performed, such as but not limited to proper ventilation and containment of blasting materials. The location shall be located within 40-mile radius of the City of Sarasota Traffic Operations storage facility located at 1761 12th Street, Sarasota, FL 34236.
5. The Contractor shall have at his place of business the necessary and proper equipment for loading and unloading items to be painted on such premises. Equipment shall be of a nature to not cause damage to the work items being loaded or unloaded. The Contractor shall be responsible for repair or replacement of any items damaged during loading or unloading procedures. The decision for an item to be repaired or replaced shall be in the sole opinion of the City Engineer, or approved designee.

U. SCHEDULING

1. Upon receipt of Notice to Proceed with a project, the successful bidder shall complete the project within the contract days of the specific work assignment. Contract days of the specific work assignment shall commence no later than Thirty (30) days after the Contractor receives the work assignment, but work shall not commence until Notice to Proceed is provided by the City of Sarasota. Notice to Proceed will not be granted until MOT plans, and other pre-construction activities have been submitted and approved.
2. Total contract time stated on each assignment shall be considered the Substantial Completion date. The Contractor shall have 14 calendar days to complete punch list items and final paperwork for closing out project.

V. WEATHER DELAYS

1. Days shall be added to the specific work assignment contract time when delays are caused by inclement weather. These delays may be caused by weather events occurring during work hours or that affect site conditions in which the Contractor may not be able to perform activities on the critical path of the schedule.
2. In a situation which the Contractor and Traffic Operations or its authorized representative do not agree in the determination of a contract day being considered as an extension of specific work assignment, the determination will be at the sole discretion of the City Engineer.

W. APPURTENANCES

1. When referenced in text, shall consist of attachments to the poles, mast arms, illuminated signs, or luminaries such as but not limited to pedestrian signal actuators and mounting

hardware.

2. Appurtenances shall be considered incidental to the work.

X. TIME AND MATERIAL

1. Bid items 38 through 40 are to be utilized for cleaning, priming and/or painting of any other structures related to traffic operations functions but that are not specifically listed on the Bid Form.
2. When material is to be paid for by the time and material method, material will be paid at Contractor's cost plus a mark-up. The mark-up may not exceed 10%. EXAMPLE: The method of calculation is as follows: Contractor's cost of material * 1.10 + tax and delivery paid by contractor = total cost to City of Sarasota.
3. As shown in the above formula example, the 10% mark-up shall be on material only and not allowed on tax, delivery, etc.

END OF SECTION

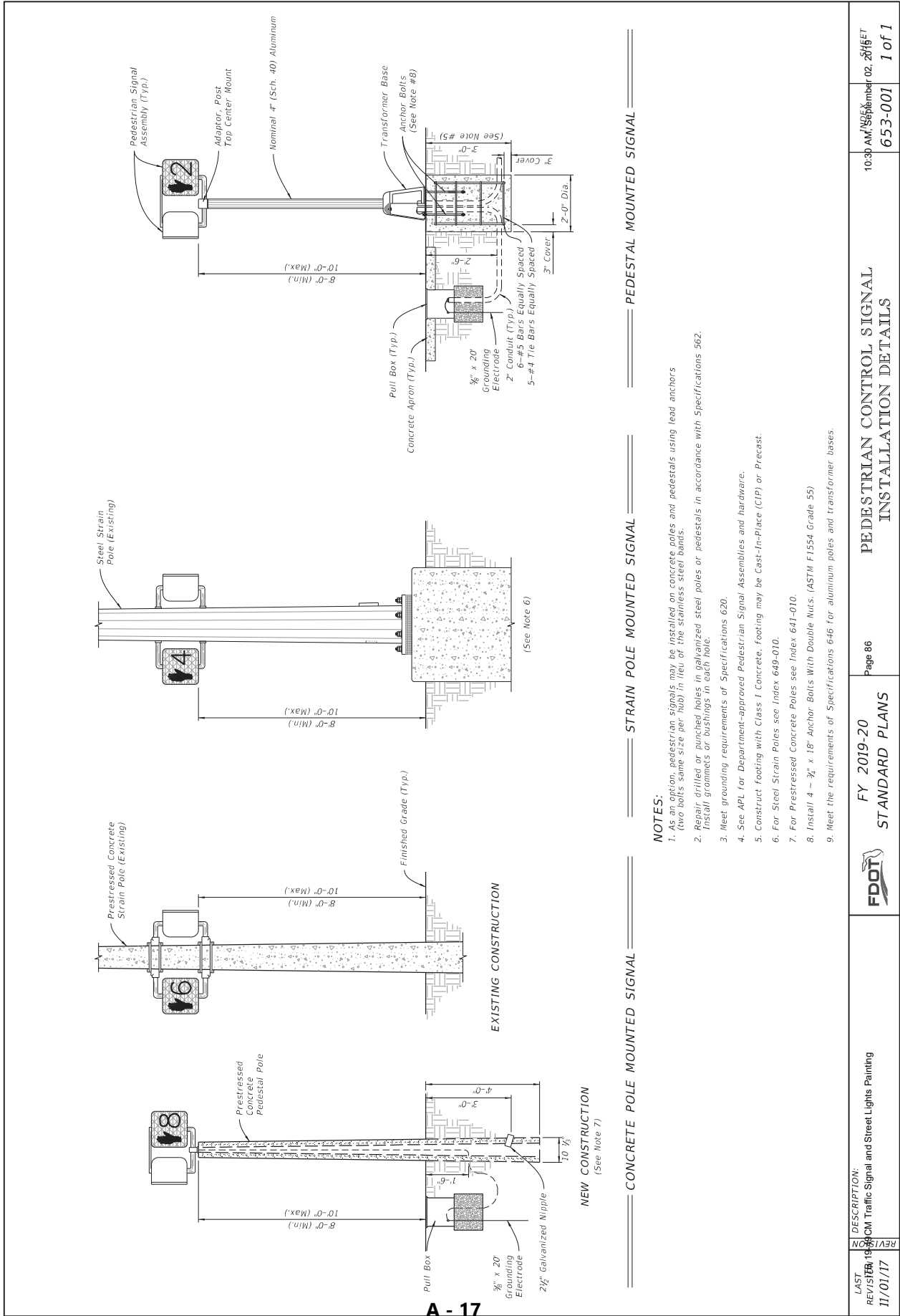

A - 17

DESCRIPTION: CON Traffic Signal and Street Lights Painting	Page 86	10:30 AM, 9/6/2018
REVISION 11/01/17	STANDARD PLANS	653-001
FDOT	FY 2019-20	1 of 1
PEDESTRIAN CONTROL SIGNAL INSTALLATION DETAILS		

LUMINAIRE:

MODEL: LAG1-YA-PF

- 50 WATT
- 70 WATT
- 100 WATT
- 175 WATT
- 250 WATT
- 400 WATT
- METAL HALIDE LAMP
- HIGH PRESSURE SODIUM

DIFFUSER:

- PATTERNED POLYCARBONATE
- ACRYLIC
- GLASS
- UVH IHBITORS

PRISMATIC GLASS REFRACTOR:

- TYPE III
- TYPE IV

ORNAMENTAL FINIAL:

- YES BRASS ORNAMENTAL
- NO

ARM BRACKETS:

- SINGLE
- DOUBLE
- TRIPLE
- QUAD

HOUSE SHIELD:

- 90 DEG.
- 135 DEG.
- 180 DEG.

INTERNAL LOUVER:

- YES
- NO

POLE:

- 1700M-1050T-XX (SPECIFY HEIGHT)
- WITH 36" STIFFENER FACTORY INSTALLED.
- 8' (SPECIAL ORDER)
- 10'
- 12'
- 14'
- 16'
- 18'

FINISH:

- TEXTURED "SARASOTA GREEN"
- UN-TEXTURED "SARASOTA GREEN"
- OTHER - SPECIFY COLOR

BY T.J. RONAN PAINT CORP. SUBMIT COLOR SAMPLE FOR APPROVAL PRIOR TO ORDERING.

NOTE: LIGHT FIXTURES TO BE PURCHASED AND SUPPLIED BY THE CITY OF SARASOTA. CONTRACTOR TO LOAD, TRANSPORT, INSTALL AND MAINTAIN UNTIL ACCEPTANCE BY THE OWNER.

DUPLEX RECEPT. ON TOP OF POLES FOR XMAS LIGHTS
DUPLEX RECEPT. IN BASE OF POLES FOR POWER LOCATED IN HAND HOLE SIDE
120V RECEPTACLES ARE FED THRU SUBPANELS SP'S

LIGHT POLE AND LUMINAIRE BY SUN VALLEY, MODEL LAG1-YA-PF

OUTSIDE EDGE OF BASE OF POLE TO BE SET 2' BACK FROM FACE OF CURB UNLESS SHOWN OTHERWISE.

NOTE: BASE OF POLE FINISH GRADE TO BE FLUSH WITH WALK OR BRICK IN NON TURF AREAS.

HAND HOLE WITH SAFETY CHAIN AND FUSE HOLDER FLOOD-SEAL HOMAC MFG. CO. PART NO. FYU-M DYU-M, 10A., 500V., FOR BOTH 480V & 120V CIRCUITS
LITTLEFUSE FLQ - OR EQUAL

3/4" x 18" ANCHOR BOLTS-GALVANIZED VERIFY BOLT TEMPLATE WITH MFG. PRIOR TO CONSTRUCTION.

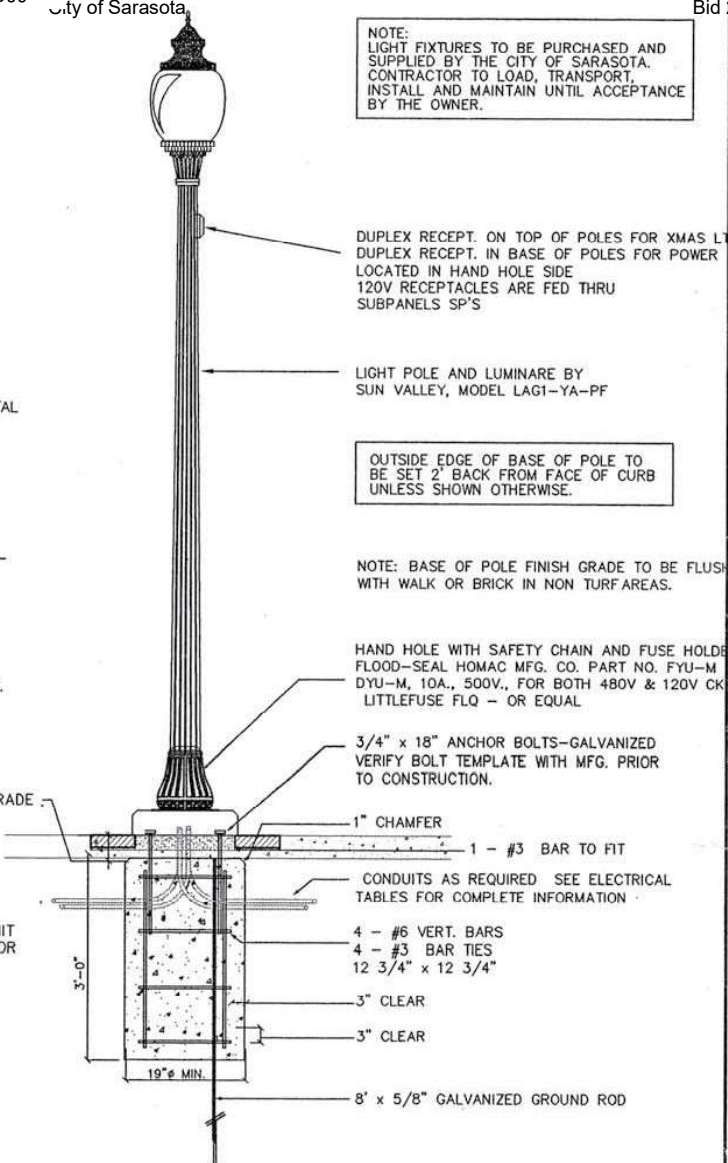

CITY OF SARASOTA STANDARD LIGHTING FIXTURE AND POLE

NTS

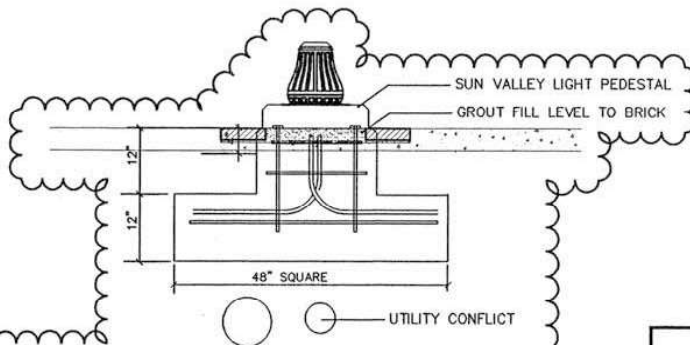

ALTERNATE BASE FOR UTILITY CONFLICTS

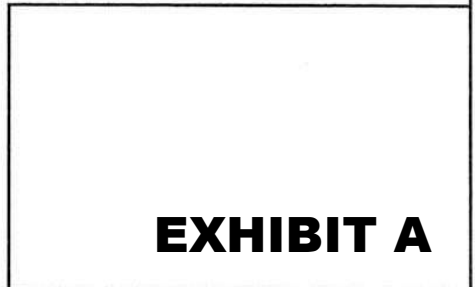

DocuSign Envelope ID: CA571A36-AAA1-4D0C-8D67-1FCC71952D00

ITEMIZED BID TABULATION
ITB #23-11JS Traffic Signal and Street Lights Painting

Item #	Description	Estimated Quantity	Units measure	Muscat Painting & Decorating	
				Unit Price	Price Extended
1	Solvent Cleaning-SSPC-SP 1, prime with Ameron's Amerlock 400, and coat with Ameron's PSX 700 (2 coats), Signal Pole (mast) approx 25 feet, Normal working hours	32	Each	\$ 789.00	\$ 25,248.00
2	Solvent Cleaning-SSPC-SP 1, prime with Ameron's Amerlock 400, and coat with Ameron's PSX 700 (2 coats), Signal Pole (mast) approx 25 feet, Other than normal working hours	2	Each	\$ 999.00	\$ 1,998.00
3	Solvent Cleaning-SSPC-SP 1, prime with Ameron's Amerlock 400, and coat with Ameron's PSX 700 (2 coats), Mast Arm up to 25 nominal feet in length, Normal working hours	4	Each	\$ 826.00	\$ 3,304.00
4	Solvent Cleaning-SSPC-SP 1, prime with Ameron's Amerlock 400, and coat with Ameron's PSX 700 (2 coats), Mast Arm up to 25 nominal feet in length, Other than normal working hours	2	Each	\$ 1,100.00	\$ 2,200.00
5	Solvent Cleaning-SSPC-SP 1, prime with Ameron's Amerlock 400, and coat with Ameron's PSX 700 (2 coats), Mast Arm 25 feet to 50 nominal feet in length, Normal working hours	20	Each	\$ 1,187.00	\$ 23,740.00
6	Solvent Cleaning-SSPC-SP 1, prime with Ameron's Amerlock 400, and coat with Ameron's PSX 700 (2 coats), Mast Arm 25 feet to 50 nominal feet in length, Other than normal working hours	2	Each	\$ 1,378.00	\$ 2,756.00
7	Solvent Cleaning-SSPC-SP 1, prime with Ameron's Amerlock 400, and coat with Ameron's PSX 700 (2 coats), Mast Arm 50 feet to 78 nominal feet in length, Normal working hours	8	Each	\$ 1,456.00	\$ 11,648.00
8	Solvent Cleaning-SSPC-SP 1, prime with Ameron's Amerlock 400, and coat with Ameron's PSX 700 (2 coats), Mast Arm 50 feet to 78 nominal feet in length, Other than normal working hours	2	Each	\$ 1,666.00	\$ 3,332.00
9	Power Tool Cleaning-SSPC-SP3, prime with Ameron 400, and coat with Ameron's PSX 700 (2 coats), Street Light Pole 30 nominal feet in height	5	Each	\$ 689.00	\$ 3,445.00
10	Solvent Cleaning-SSPC-SP 1, prime with Ameron's Amerlock 400, and coat with Ameron's PSX 700 (2 coats), Pedestrian Pole (see typical pedestrian pole sheet)	10	Each	\$ 489.00	\$ 4,890.00
11	Solvent Cleaning-SSPC-SP 1, prime with Ameron's Amerlock 400, and coat with Ameron's PSX 700 (2 coats), Sign Housing, in conjunction with other work. Housing 4 feet to 8 feet in length and 20 inches to 36 inches in height.	14	Each	\$ 278.00	\$ 3,892.00

DocuSign Envelope ID: CA571A36-AAA1-4D0C-8D67-1FCC71952D00

**ITEMIZED BID TABULATION
ITB #23-11JS Traffic Signal and Street Lights Painting**

Item #	Description	Estimated Quantity	Units measure	Muscat Painting & Decorating	
				Unit Price	Price Extended
12	Solvent Cleaning-SSPC-SP 1, prime with Ameron's Amerlock 400, and coat with Ameron's PSX 700 (2 coats), Signal Head	24	Each	\$ 140.00	\$ 3,360.00
13	Power Tool Cleaning-SSPC-SP3, prime with Ameron's Amerlock 400, and coat with Ameron's PSX 700 (2 coats), Signal Pole (mast) approx 25 ft, Normal working hours	32	Each	\$ 978.00	\$ 31,296.00
14	Power Tool Cleaning-SSPC-SP3, prime with Ameron's Amerlock 400, and coat with Ameron's PSX 700 (2 coats), Signal Pole (mast) approx 25 ft, Other than normal working hours	2	Each	\$ 1,178.00	\$ 2,356.00
15	Power Tool Cleaning-SSPC-SP3, prime with Ameron's Amerlock 400, and coat with Ameron's PSX 700 (2 coats), Mast Arm up to 25 nominal feet in length, Normal working hours	4	Each	\$ 1,389.00	\$ 5,556.00
16	Power Tool Cleaning-SSPC-SP3, prime with Ameron's Amerlock 400, and coat with Ameron's PSX 700 (2 coats), Mast Arm up to 25 nominal feet in length, Other than normal working hours	2	Each	\$ 1,589.00	\$ 3,178.00
17	Power Tool Cleaning-SSPC-SP3, prime with Ameron's Amerlock 400, and coat with Ameron's PSX 700 (2 coats), Mast Arm 25 feet to 50 nominal feet in length, Normal working hours	20	Each	\$ 1,649.00	\$ 32,980.00
18	Power Tool Cleaning-SSPC-SP3, prime with Ameron's Amerlock 400, and coat with Ameron's PSX 700 (2 coats), Mast Arm 25 feet to 50 nominal feet in length, Other than normal working hours	2	Each	\$ 1,915.00	\$ 3,830.00
19	Power Tool Cleaning-SSPC-SP3, prime with Ameron's Amerlock 400, and coat with Ameron's PSX 700 (2 coats), Mast Arm 50 feet to 78 nominal feet in length, Normal working hours	8	Each	\$ 2,023.00	\$ 16,184.00
20	Power Tool Cleaning-SSPC-SP3, prime with Ameron's Amerlock 400, and coat with Ameron's PSX 700 (2 coats), Mast Arm 50 feet to 78 nominal feet in length, Other than normal working hours	2	Each	\$ 2,315.00	\$ 4,630.00

DocuSign Envelope ID: CA571A36-AAA1-4D0C-8D67-1FCC71952D00

**ITEMIZED BID TABULATION
ITB #23-11JS Traffic Signal and Street Lights Painting**

Item #	Description	Estimated Quantity	Units measure	Muscat Painting & Decorating	
				Unit Price	Price Extended
21	Commercial Blast Cleaning -SSPC-SP6, prime with Amerlock 400 and coat with Ameron's PSX 700 (2 coats), Street Light Pole 30 nominal feet in height	4	Each	\$ 1,240.00	\$ 4,960.00
22	Power Tool Cleaning-SSPC-SP3, prime with Ameron's Amerlock 400, and coat with Ameron's PSX 700 (2 coats), Pedestrian Pole (see typical pedestrian pole sheet)	24	Each	\$ 679.00	\$ 16,296.00
23	Power Tool Cleaning-SSPC-SP3, prime with Ameron's Amerlock 400, and coat with Ameron's PSX 700 (2 coats), Sign Housing, in conjunction with other work. Housing 4 feet to 8 feet in length and 20 inches to 36 inches in height.	16	Each	\$ 386.00	\$ 6,176.00
24	Power Tool Cleaning-SSPC-SP3, prime with Ameron's Amerlock 400, and coat with Ameron's PSX 700 (2 coats), Signal Head	24	Each	\$ 194.00	\$ 4,656.00
25	Commercial Blast Cleaning-SSPC-SP6, prime with Ameron's Amerlock 400, and coat with Ameron's PSX 700 (2 coats), Signal Pole (mast) approx 25 ft, Normal working hours	32	Each	\$ 1,760.00	\$ 56,320.00
26	Commercial Blast Cleaning-SSPC-SP6, prime with Ameron's Amerlock 400, and coat with Ameron's PSX 700 (2 coats), Signal Pole (mast) approx 25 ft, Other than normal working hours	2	Each	\$ 2,116.00	\$ 4,232.00
27	Commercial Blast Cleaning-SSPC-SP6, prime with Ameron's Amerlock 400, and coat with Ameron's PSX 700 (2 coats), Mast Arm up to 25 nominal feet in length, Normal working hours	4	Each	\$ 2,497.00	\$ 9,988.00
28	Commercial Blast Cleaning-SSPC-SP6, prime with Ameron's Amerlock 400, and coat with Ameron's PSX 700 (2 coats), Mast Arm up to 25 nominal feet in length, Other than normal working hours	2	Each	\$ 2,860.00	\$ 5,720.00
29	Commercial Blast Cleaning-SSPC-SP6, prime with Ameron's Amerlock 400, and coat with Ameron's PSX 700 (2 coats), Mast Arm 25 feet to 50 nominal feet in length, Normal working hours	20	Each	\$ 2,968.00	\$ 59,360.00
30	Commercial Blast Cleaning-SSPC-SP6, prime with Ameron's Amerlock 400, and coat with Ameron's PSX 700 (2 coats), Mast Arm 25 feet to 50 nominal feet in length, Other than normal working hours	2	Each	\$ 6,894.00	\$ 13,788.00

DocuSign Envelope ID: CA571A36-AAA1-4D0C-8D67-1FCC71952D00

**ITEMIZED BID TABULATION
ITB #23-11JS Traffic Signal and Street Lights Painting**

Item #	Description	Estimated Quantity	Units measure	Muscat Painting & Decorating	
				Unit Price	Price Extended
31	Commercial Blast Cleaning-SSPC-SP6, prime with Ameron's Amerlock 400, and coat with Ameron's PSX 700 (2 coats), Mast Arm 50 feet to 78 nominal feet in length, Normal working hours	8	Each	\$ 2,678.00	\$ 21,424.00
32	Commercial Blast Cleaning-SSPC-SP6, prime with Ameron's Amerlock 400, and coat with Ameron's PSX 700 (2 coats), Mast Arm 50 feet to 78 nominal feet in length, Other than normal working hours	2	Each	\$ 2,878.00	\$ 5,756.00
33	Commercial Blast Cleaning-SSPC-SP6, prime with Ameron's Amerlock 400, and coat with Ameron's PSX 700 (2 coats), Pedestrian Pole (see typical pedestrian pole sheet)	24	Each	\$ 715.00	\$ 17,160.00
34	Commercial Blast Cleaning-SSPC-SP6, prime with Ameron's Amerlock 400, and coat with Ameron's PSX 700 (2 coats), Sign Housing, in conjunction with other work. Housing 4 feet to 8 feet in length and 20 inches to 36 inches in height.	16	Each	\$ 421.00	\$ 6,736.00
35	Solvent Cleaning-SSPC-SP 1, prime with Ameron's Amerlock 400, and coat with Ameron's PSX 700 (2 coats), Decorative Street Light Pole 12 ft (see typical decorative Pole Sheet)	32	Each	\$ 389.00	\$ 12,448.00
36	Commercial Blast Cleaning-SSPC-SP6, prime with Ameron's Amerlock 400, and coat with Ameron's PSX 700 (2 coats), Decorative Street Light Pole 12 ft	32	Each	\$ 789.00	\$ 25,248.00
37	Solvent Cleaning-SSPC-SP 1, prime with Ameron's Amerlock 400, and coat with Ameron's PSX 700 (2 coats), Street Light Pole 30 nominal feet in height	5	Each	\$ 829.00	\$ 4,145.00
38	Qualified Cleaner (Blast) with all necessary equipment	300	Ft.	\$ 8.00	\$ 2,400.00
39	Qualified Cleaner (Solvent or Power Tool) with all necessary equipment	300	Ft.	\$ 6.00	\$ 1,800.00
40	Qualified Painter with all necessary equipment	300	Ft.	\$ 2.00	\$ 600.00
41	Material Mark-up (not to exceed 10%)				0.00%
TOTAL BID PRICE (Sum of item totals 1 thru 40)					\$ 469,036.00

Certificate Of Completion

Envelope Id: CA571A36AAA14D0C8D671FCC71952D00
 Subject: Complete with DocuSign: 23-11JS Contract Agreement_Muscat Painting.pdf
 Source Envelope:
 Document Pages: 22 Signatures: 4
 Certificate Pages: 6 Initials: 0
 AutoNav: Enabled
 Envelopeld Stamping: Enabled
 Time Zone: (UTC-05:00) Eastern Time (US & Canada)

Status: Completed

 Envelope Originator:
 Jessica Smith
 1565 1st Street
 Sarasota, FL 34236
 Jessica.Smith@sarasotaFL.gov
 IP Address: 163.116.250.41

Record Tracking

Status: Original Holder: Jessica Smith Location: DocuSign
 2/23/2023 9:04:42 AM Jessica.Smith@sarasotaFL.gov

Signer Events

Dennis Hughes
 dennis.hughes@sarasotafl.gov
 Traffic Tech II
 Security Level: Email, Account Authentication (Optional)
Electronic Record and Signature Disclosure:
 Accepted: 2/23/2023 10:26:41 AM
 ID: df7cf26e-4bdd-4bcf-a764-6dcfd08a0b85

Signature
Completed

 Using IP Address: 199.181.82.4

Timestamp
 Sent: 2/23/2023 9:12:44 AM
 Viewed: 2/23/2023 10:26:41 AM
 Signed: 2/23/2023 10:27:37 AM

Brett Muscat
 brett@muscatpainting.com
 x
 Muscat Painting & Decorating
 555 Ashland Avenue
 East Dundee, Illinois
 Security Level: Email, Account Authentication (Optional)
Electronic Record and Signature Disclosure:
 Accepted: 2/23/2023 11:04:19 AM
 ID: e745b922-3e8c-4f25-a6f3-6b6e5b84534f

DocuSigned by:

 B9C72D8E78EC401...

 Signature Adoption: Pre-selected Style
 Using IP Address: 73.22.145.135

Sent: 2/23/2023 10:27:42 AM
 Viewed: 2/23/2023 11:04:19 AM
 Signed: 2/23/2023 11:04:29 AM

Jessica Smith
 Jessica.Smith@sarasotaFL.gov
 City of Sarasota
 Security Level: Email, Account Authentication (Optional)
Electronic Record and Signature Disclosure:
 Not Offered via DocuSign

Completed

 Using IP Address: 163.116.250.44

Sent: 2/23/2023 11:04:33 AM
 Viewed: 3/20/2023 9:52:40 AM
 Signed: 3/20/2023 9:52:49 AM

Lauren Sullivan
 Lauren.Sullivan@sarasotaFL.gov
 City of Sarasota
 Signing Group: CAC Contract Processing
 Security Level: Email, Account Authentication (Optional)
Electronic Record and Signature Disclosure:
 Not Offered via DocuSign

Completed

 Using IP Address: 199.181.82.4

Sent: 3/20/2023 9:52:51 AM
 Viewed: 3/20/2023 11:55:41 AM
 Signed: 3/20/2023 11:58:44 AM

Exhibit A - Sarasota Agreement

CONTRACT# PWD/260259

Envelope Summary Events

Status

Timestamps

Completed

Security Checked

3/22/2023 10:12:48 AM

Payment Events

Status

Timestamps

Electronic Record and Signature Disclosure

Electronic Record and Signature Disclosure created on: 2/14/2019 1:49:42 PM

Parties agreed to: Dennis Hughes, Brett Muscat

ELECTRONIC RECORD AND SIGNATURE DISCLOSURE

From time to time, City of Sarasota (we, us or Company) may be required by law to provide to you certain written notices or disclosures. Described below are the terms and conditions for providing to you such notices and disclosures electronically through the DocuSign system. Please read the information below carefully and thoroughly, and if you can access this information electronically to your satisfaction and agree to this Electronic Record and Signature Disclosure (ERSD), please confirm your agreement by selecting the check-box next to 'I agree to use electronic records and signatures' before clicking 'CONTINUE' within the DocuSign system.

Getting paper copies

At any time, you may request from us a paper copy of any record provided or made available electronically to you by us. You will have the ability to download and print documents we send to you through the DocuSign system during and immediately after the signing session and, if you elect to create a DocuSign account, you may access the documents for a limited period of time (usually 30 days) after such documents are first sent to you. After such time, if you wish for us to send you paper copies of any such documents from our office to you, you will be charged a \$0.00 per-page fee. You may request delivery of such paper copies from us by following the procedure described below.

Withdrawing your consent

If you decide to receive notices and disclosures from us electronically, you may at any time change your mind and tell us that thereafter you want to receive required notices and disclosures only in paper format. How you must inform us of your decision to receive future notices and disclosure in paper format and withdraw your consent to receive notices and disclosures electronically is described below.

Consequences of changing your mind

If you elect to receive required notices and disclosures only in paper format, it will slow the speed at which we can complete certain steps in transactions with you and delivering services to you because we will need first to send the required notices or disclosures to you in paper format, and then wait until we receive back from you your acknowledgment of your receipt of such paper notices or disclosures. Further, you will no longer be able to use the DocuSign system to receive required notices and consents electronically from us or to sign electronically documents from us.

All notices and disclosures will be sent to you electronically

Unless you tell us otherwise in accordance with the procedures described herein, we will provide electronically to you through the DocuSign system all required notices, disclosures, authorizations, acknowledgements, and other documents that are required to be provided or made available to you during the course of our relationship with you. To reduce the chance of you inadvertently not receiving any notice or disclosure, we prefer to provide all of the required notices and disclosures to you by the same method and to the same address that you have given us. Thus, you can receive all the disclosures and notices electronically or in paper format through the paper mail delivery system. If you do not agree with this process, please let us know as described below. Please also see the paragraph immediately above that describes the consequences of your electing not to receive delivery of the notices and disclosures electronically from us.

How to contact City of Sarasota:

You may contact us to let us know of your changes as to how we may contact you electronically, to request paper copies of certain information from us, and to withdraw your prior consent to receive notices and disclosures electronically as follows:

To contact us by email send messages to: herminio.rodriguez@sarasotafl.gov

To advise City of Sarasota of your new email address

To let us know of a change in your email address where we should send notices and disclosures electronically to you, you must send an email message to us at herminio.rodriguez@sarasotafl.gov and in the body of such request you must state: your previous email address, your new email address. We do not require any other information from you to change your email address.

If you created a DocuSign account, you may update it with your new email address through your account preferences.

To request paper copies from City of Sarasota

To request delivery from us of paper copies of the notices and disclosures previously provided by us to you electronically, you must send us an email to herminio.rodriguez@sarasotafl.gov and in the body of such request you must state your email address, full name, mailing address, and telephone number. We will bill you for any fees at that time, if any.

To withdraw your consent with City of Sarasota

To inform us that you no longer wish to receive future notices and disclosures in electronic format you may:

- i. decline to sign a document from within your signing session, and on the subsequent page, select the check-box indicating you wish to withdraw your consent, or you may;
- ii. send us an email to herminio.rodriguez@sarasotafl.gov and in the body of such request you must state your email, full name, mailing address, and telephone number. We do not need any other information from you to withdraw consent.. The consequences of your withdrawing consent for online documents will be that transactions may take a longer time to process..

Required hardware and software

The minimum system requirements for using the DocuSign system may change over time. The current system requirements are found here: <https://support.docusign.com/guides/signer-guide-signing-system-requirements>.

Acknowledging your access and consent to receive and sign documents electronically

To confirm to us that you can access this information electronically, which will be similar to other electronic notices and disclosures that we will provide to you, please confirm that you have read this ERSD, and (i) that you are able to print on paper or electronically save this ERSD for your future reference and access; or (ii) that you are able to email this ERSD to an email address where you will be able to print on paper or save it for your future reference and access. Further, if you consent to receiving notices and disclosures exclusively in electronic format as described herein, then select the check-box next to 'I agree to use electronic records and signatures' before clicking 'CONTINUE' within the DocuSign system.

By selecting the check-box next to 'I agree to use electronic records and signatures', you confirm that:

- You can access and read this Electronic Record and Signature Disclosure; and
- You can print on paper this Electronic Record and Signature Disclosure, or save or send this Electronic Record and Disclosure to a location where you can print it, for future reference and access; and
- Until or unless you notify City of Sarasota as described above, you consent to receive exclusively through electronic means all notices, disclosures, authorizations, acknowledgements, and other documents that are required to be provided or made available to you by City of Sarasota during the course of your relationship with City of Sarasota.

Certificate Of Completion

Envelope Id: 23E8B2AB-51EF-4ADE-B673-D3D253E93584

Status: Completed

Subject: FOR SIGNATURE-Cooperative Purchasing Agreement for Traffic Signal&Street Light Painting-PWD/260259:

Source Envelope:

Document Pages: 37

Signatures: 4

Envelope Originator:

Certificate Pages: 5

Initials: 0

Amber Bartleson

AutoNav: Enabled

110 SE Watula Avenue

Envelopeld Stamping: Enabled

City Hall, Third Floor

Time Zone: (UTC-05:00) Eastern Time (US & Canada)

Ocala, FL 34471

abartleson@ocalafl.gov

IP Address: 216.255.240.104

Record Tracking

Status: Original

Holder: Amber Bartleson

Location: DocuSign

2/11/2026 2:52:33 PM

abartleson@ocalafl.gov

Security Appliance Status: Connected

Pool: StateLocal

Storage Appliance Status: Connected

Pool: City of Ocala - Procurement & Contracting

Location: Docusign

Signer Events

Muscat Painting & Decorating

brett@muscatpainting.com

Administrator

Security Level: Email, Account Authentication (None)

Signature

DocuSigned by:

Muscat Painting & Decorating

B9C72D8E78EC401...

Timestamp

Sent: 2/11/2026 2:55:05 PM

Viewed: 2/13/2026 8:57:44 AM

Signed: 2/13/2026 8:58:52 AM

Signature Adoption: Pre-selected Style

Using IP Address:

2601:240:4501:be30:6020:3363:c31b:dedb

Electronic Record and Signature Disclosure:

Accepted: 2/13/2026 8:57:44 AM

ID: d48dec74-5ddd-41a1-968e-a4809f089fd6

William E. Sexton, Esq.

wsexton@ocalafl.gov

City Attorney

Security Level: Email, Account Authentication (None)

Signed by:

William E. Sexton, Esq.

4A55AB8A8ED04F3...

Sent: 2/13/2026 8:58:54 AM

Viewed: 2/13/2026 4:52:08 PM

Signed: 2/13/2026 4:53:01 PM

Signature Adoption: Pre-selected Style

Using IP Address: 216.255.240.104

Electronic Record and Signature Disclosure:

Accepted: 9/15/2023 9:02:35 AM

ID: 313dc6f2-e1d0-44c3-8305-6c087d6cdf0b

Ken Whitehead

kwhitehead@ocalafl.org

Assistant City Manager

City of Ocala

Security Level: Email, Account Authentication (None)

DocuSigned by:

Ken Whitehead

5677F71E38874F4...

Sent: 2/13/2026 4:53:02 PM

Viewed: 2/16/2026 3:31:58 PM

Signed: 2/16/2026 4:21:54 PM

Signature Adoption: Pre-selected Style

Using IP Address: 216.255.240.104

Electronic Record and Signature Disclosure:

Not Offered via Docusign

Angel B. Jacobs

ajacobs@ocalafl.org

City Clerk

Security Level: Email, Account Authentication (None)

Signed by:

Angel B. Jacobs

8DB3574C28E54A5...

Sent: 2/16/2026 4:21:55 PM

Viewed: 2/16/2026 4:59:50 PM

Signed: 2/16/2026 5:00:06 PM

Signature Adoption: Pre-selected Style

Using IP Address: 216.255.240.104

Signer Events	Signature	Timestamp
----------------------	------------------	------------------

Electronic Record and Signature Disclosure:
Accepted: 2/16/2026 4:59:50 PM
ID: b18bcb2a-01de-447e-9ece-bf14ff1c20ad

In Person Signer Events	Signature	Timestamp
--------------------------------	------------------	------------------

Editor Delivery Events	Status	Timestamp
-------------------------------	---------------	------------------

Agent Delivery Events	Status	Timestamp
------------------------------	---------------	------------------

Intermediary Delivery Events	Status	Timestamp
-------------------------------------	---------------	------------------

Certified Delivery Events	Status	Timestamp
----------------------------------	---------------	------------------

Carbon Copy Events	Status	Timestamp
---------------------------	---------------	------------------

Witness Events	Signature	Timestamp
-----------------------	------------------	------------------

Notary Events	Signature	Timestamp
----------------------	------------------	------------------

Envelope Summary Events	Status	Timestamps
--------------------------------	---------------	-------------------

Envelope Sent	Hashed/Encrypted	2/11/2026 2:55:05 PM
Certified Delivered	Security Checked	2/16/2026 4:59:50 PM
Signing Complete	Security Checked	2/16/2026 5:00:06 PM
Completed	Security Checked	2/16/2026 5:00:06 PM

Payment Events	Status	Timestamps
-----------------------	---------------	-------------------

Electronic Record and Signature Disclosure

ELECTRONIC RECORD AND SIGNATURE DISCLOSURE

From time to time, City of Ocala - Procurement & Contracting (we, us or Company) may be required by law to provide to you certain written notices or disclosures. Described below are the terms and conditions for providing to you such notices and disclosures electronically through the DocuSign system. Please read the information below carefully and thoroughly, and if you can access this information electronically to your satisfaction and agree to this Electronic Record and Signature Disclosure (ERSD), please confirm your agreement by selecting the check-box next to 'I agree to use electronic records and signatures' before clicking 'CONTINUE' within the DocuSign system.

Getting paper copies

At any time, you may request from us a paper copy of any record provided or made available electronically to you by us. You will have the ability to download and print documents we send to you through the DocuSign system during and immediately after the signing session and, if you elect to create a DocuSign account, you may access the documents for a limited period of time (usually 30 days) after such documents are first sent to you. After such time, if you wish for us to send you paper copies of any such documents from our office to you, you will be charged a \$0.00 per-page fee. You may request delivery of such paper copies from us by following the procedure described below.

Withdrawing your consent

If you decide to receive notices and disclosures from us electronically, you may at any time change your mind and tell us that thereafter you want to receive required notices and disclosures only in paper format. How you must inform us of your decision to receive future notices and disclosure in paper format and withdraw your consent to receive notices and disclosures electronically is described below.

Consequences of changing your mind

If you elect to receive required notices and disclosures only in paper format, it will slow the speed at which we can complete certain steps in transactions with you and delivering services to you because we will need first to send the required notices or disclosures to you in paper format, and then wait until we receive back from you your acknowledgment of your receipt of such paper notices or disclosures. Further, you will no longer be able to use the DocuSign system to receive required notices and consents electronically from us or to sign electronically documents from us.

All notices and disclosures will be sent to you electronically

Unless you tell us otherwise in accordance with the procedures described herein, we will provide electronically to you through the DocuSign system all required notices, disclosures, authorizations, acknowledgements, and other documents that are required to be provided or made available to you during the course of our relationship with you. To reduce the chance of you inadvertently not receiving any notice or disclosure, we prefer to provide all of the required notices and disclosures to you by the same method and to the same address that you have given us. Thus, you can receive all the disclosures and notices electronically or in paper format through the paper mail delivery system. If you do not agree with this process, please let us know as described below. Please also see the paragraph immediately above that describes the consequences of your electing not to receive delivery of the notices and disclosures electronically from us.

How to contact City of Ocala - Procurement & Contracting:

You may contact us to let us know of your changes as to how we may contact you electronically, to request paper copies of certain information from us, and to withdraw your prior consent to receive notices and disclosures electronically as follows:

To contact us by email send messages to: contracts@ocalafl.org

To advise City of Ocala - Procurement & Contracting of your new email address

To let us know of a change in your email address where we should send notices and disclosures electronically to you, you must send an email message to us at contracts@ocalafl.org and in the body of such request you must state: your previous email address, your new email address. We do not require any other information from you to change your email address.

If you created a DocuSign account, you may update it with your new email address through your account preferences.

To request paper copies from City of Ocala - Procurement & Contracting

To request delivery from us of paper copies of the notices and disclosures previously provided by us to you electronically, you must send us an email to contracts@ocalafl.org and in the body of such request you must state your email address, full name, mailing address, and telephone number. We will bill you for any fees at that time, if any.

To withdraw your consent with City of Ocala - Procurement & Contracting

To inform us that you no longer wish to receive future notices and disclosures in electronic format you may:

- i. decline to sign a document from within your signing session, and on the subsequent page, select the check-box indicating you wish to withdraw your consent, or you may;
- ii. send us an email to contracts@ocalafl.org and in the body of such request you must state your email, full name, mailing address, and telephone number. We do not need any other information from you to withdraw consent.. The consequences of your withdrawing consent for online documents will be that transactions may take a longer time to process..

Required hardware and software

The minimum system requirements for using the DocuSign system may change over time. The current system requirements are found here: <https://support.docusign.com/guides/signer-guide-signing-system-requirements>.

Acknowledging your access and consent to receive and sign documents electronically

To confirm to us that you can access this information electronically, which will be similar to other electronic notices and disclosures that we will provide to you, please confirm that you have read this ERSD, and (i) that you are able to print on paper or electronically save this ERSD for your future reference and access; or (ii) that you are able to email this ERSD to an email address where you will be able to print on paper or save it for your future reference and access. Further, if you consent to receiving notices and disclosures exclusively in electronic format as described herein, then select the check-box next to ‘I agree to use electronic records and signatures’ before clicking ‘CONTINUE’ within the DocuSign system.

By selecting the check-box next to ‘I agree to use electronic records and signatures’, you confirm that:

- You can access and read this Electronic Record and Signature Disclosure; and
- You can print on paper this Electronic Record and Signature Disclosure, or save or send this Electronic Record and Disclosure to a location where you can print it, for future reference and access; and
- Until or unless you notify City of Ocala - Procurement & Contracting as described above, you consent to receive exclusively through electronic means all notices, disclosures, authorizations, acknowledgements, and other documents that are required to be provided or made available to you by City of Ocala - Procurement & Contracting during the course of your relationship with City of Ocala - Procurement & Contracting.